

Topics in Chemistry

Answer the questions below to familiarize yourself with topics in chemistry that were not covered this year in class. You may use your textbook or the internet to find the information you need to answer the questions. Search engines such as Google, or chemistry sites such as Evan's Regents Chemistry Corner are good sources of information.

Solutions

Answer the questions below using *Table G*.

- _____ 1. A saturated solution of potassium nitrate is prepared at 60°C using 200 mL of water. If the solution is cooled to 30°C, how many grams will precipitate out of the solution?
- _____ 2. At what temperature do potassium nitrate and sodium nitrate have the same solubility?

- _____ 3. What is the concentration of 45 mL of a solution containing 9.0 g of KClO_3 ?
- _____ 4. A solution is prepared by mixing 20.0 g of NaNO_3 with 100. mL of water. What is the percentage mass of the solution? (Assume density of water is 1 g/mL)
- _____ 5. A 250. mL sample of air at STP contains approximately 52.5 mL of $\text{O}_2(g)$. What is the percentage of oxygen in air?
- _____ 6. A polar solvent is prepared by mixing 27.5 mL of propanone with 222.5 mL of water. What is the percentage by volume of propanone in the mixture?
- _____ 7. How many parts per million of sulfur dioxide are there in a solution containing 0.065 g of sulfur dioxide in 5,000 mL of water? (Assume density of water is 1 g/mL)
- _____ 8. Determine the molarity of 500. mL of a solution with 0.35 mol of dissolved solute.
- _____ 9. A 200. mL sample of a solution contains 4.0 g of NaOH. What is its molarity?
- _____ 10. How many grams of KNO_3 are needed to prepare 25 mL of a 2.0 M solution?

Acids, Bases, and Salts

- _____ 11. How much 6.0 M HNO_3 is needed to neutralize 39 mL of 2.0 M KOH?
- _____ 12. How much 3.0 M NaOH is needed to neutralize 30. mL of 0.75 M H_2SO_4 ?
- _____ 13. What is the concentration of 20 mL of LiOH if it is neutralized by 60 mL of 4 M HCl?

Redox and Electrochemistry

Write the half reactions for each of the redox reactions below:

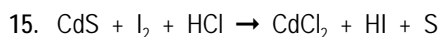
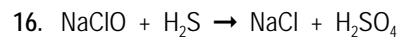
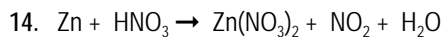

Organic Chemistry

Name the compound below and draw its condensed structural formula

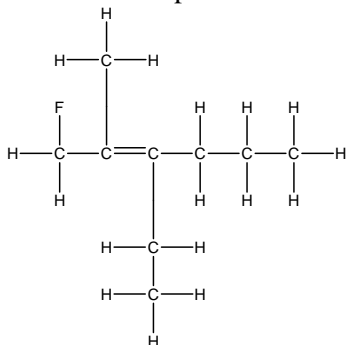

17. Name: _____

18. Condensed Structural Formula (Graphic Formula):
_____**Nuclear Chemistry**Write a complete nuclear equation showing the transmutation that occurs. Use *Table N* for reference.

19. What forms when carbon-14 decays?

20. What forms when radium-226 decays?

21. What forms when iron-53 decays?

Answer the questions below using data from *Table N*, the table of *Selected Radioisotopes*22. How long will it take for 30 g of ^{222}Rn to decay to 7.5 g?23. How many grams of ^{16}N will be left from a 16 g sample after 21.6 s?24. How long will it take for a 28 g sample of ^{226}Ra to decay to 3.5 g?**Nuclear Reactors**

25. Draw and label the parts of a nuclear reactor. Explain the function of the parts

Nuclear reactor